



Welding Table S-1000/N/L/A

1000m³h@Hood

Heavy Duty Table

Down Draft Exhaust

Small Revolving Table

Arm Diameter: 160mm

Arm Lengths: 2m



Welding Station for capturing:

- **WELDING FUMES**
- **GRINDING DUSTS**
- **DRY DUSTS**
- **SOLDERING DUSTS**

and many more...

Welding Table S-1000/N/L/A

S1000 welding table has been designed to exhaust fumes appearing during the welding process. Oskar's welding table makes perfect work space featuring fume arm an down draft exhaust which captures dangerous fumes. Supplied arm can be fitted with optional lighth kit and automatic photosensor, which can activate the fan unit, giving you the freedom to work efficiently and effectively. S1000 also features small round revolving table to give flexibility and easy access to the welded elements. Design of the table allows you to connect it to the central filtering system. Welding table can work with most dry dusts and fumes with restrictions to chemically aggressive or explosive gases.



Working Area

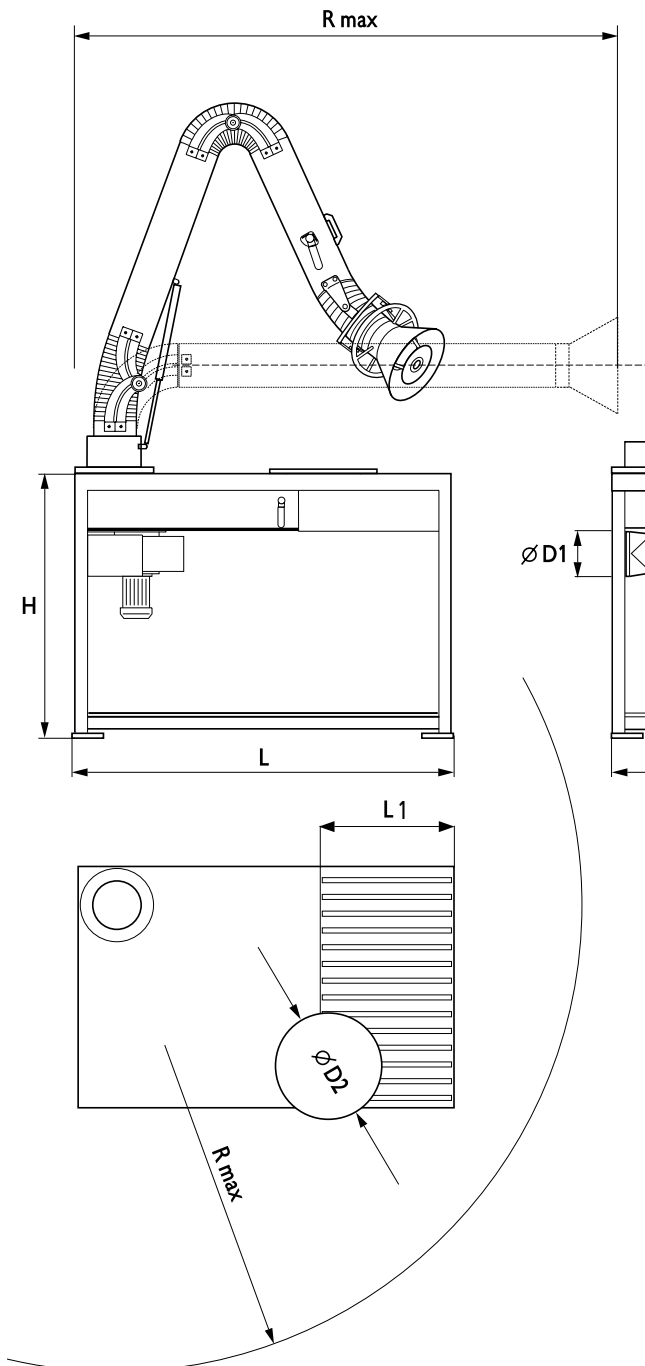

Working area (with arm 1620P).

Dimensions

Dimensions	Unit	
L	[in] / [mm]	49.6 / 1260
S	[in] / [mm]	33.9 / 860
H	[in] / [mm]	33.7 / 855
L1	[in] / [mm]	15.7 / 400
D1	[in] / [mm]	6.3 / 160
D2	[in] / [mm]	13.8 / 350
R max (for 1620P)	[ft.] / [m]	6.56 / 2

Construction Features

- Heavy Duty welded construction
- Additional revolving round table
- Built in downdraft exhaust
- Two separate dampers (arm & bench)
- 0,75kW Motor
- Multiple motor voltages available
- Thermal overload for motor
- Possibility to connect to central filtering system

Performance Features

- Arm supplied as standard 160mm x 2m
- 76dB(a) level @ 1m
- Manual dampers allow to control the air flow

Technical Data

SF-1000		
Airflow with arm*	[cfm] / [m³/h]	600 / 1000
Weight 1 (without arm)	[lb] / [kg]	265 / 120
Weight 2 (with arm 1620P)	[lb] / [kg]	309 / 140
Motor power supply (voltage)	[V] / phase / [Hz]	380 / 3 / 50
Motor power	[HP] / [kW]	1 / 0.75

Configurations

S1000 Type	Light-kit	Exhaust Control
W00-01-S1000N	None	Manual
W00-01-S1000L	Halogen light in the hood	Manual
W00-01-S1000A	Halogen light in the hood	Automatic (photosensor)

Welding Table S-1000/N/L/A