

Product:	Fixed extension boom Ø160	
Index:	W06-02-10160	

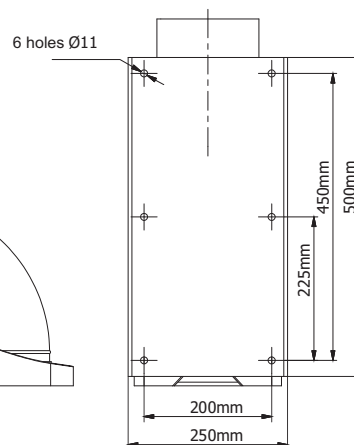

Features:

- galvanized spiro tube on the support beam
- heavy duty steel closed profile support beams, metal rod counter support and inlet socket for 160 series extraction arms
- all supports and adjustments on the outside
- welded steel boom mounting bracket with top or bottom outlets and ready for top fan unit mounting (does not include fixed booms)
- rigid sliding bearing at boom mounting bracket hinge
- black PVC elastic hoses (temperature resistance up to 80°C)

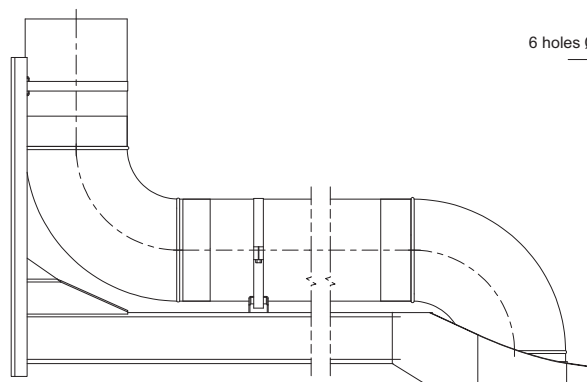
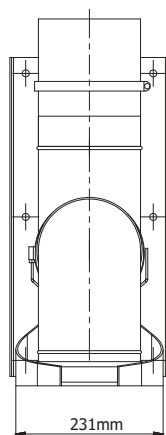
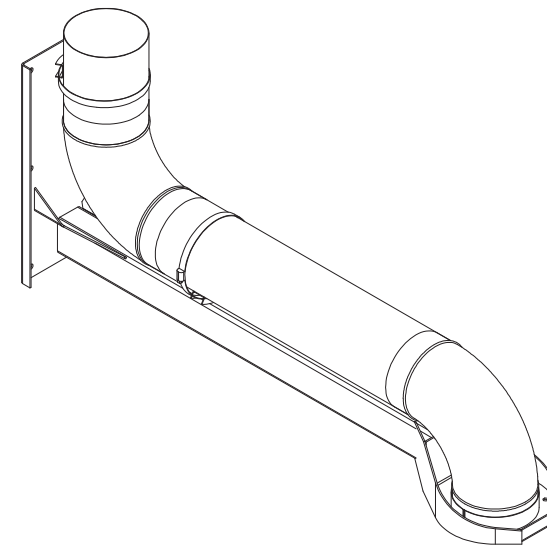
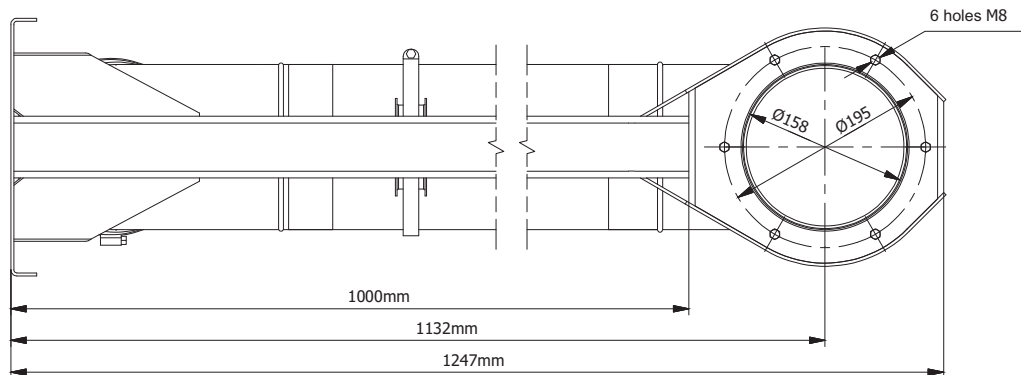